

VOYAGER HIGH EFFICIENCY GAS FIRED WATER HEATERS

THE NEW DIMENSION IN WATER HEATING TECHNOLOGY!

The Voyager high efficiency gas fired water heater is truly a unique appliance. The Voyager system is designed with the most advanced technology available. This use of modern technology optimizes the efficiency and operating reliability of each Voyager. The endless features will provide each customer with maximum savings on operation, space, and installation. The Voyager high efficiency gas fired water heater is setting a new dimension in water heating technology.

FEATURES

- 316L stainless steel construction
- 10 years warranty on residential applications; 6 years on commercial applications; and 6 years on components for residential and commercial applications. Other warranties are available, call factory.
- No chimney required; direct venting plastic pipe - easy to install, operate, and service
- Multiple heater installation for increased capacity
- Units may be stacked to save space.
- Compact design eliminates need for bulky storage tanks
- Efficiency of 95% dramatically reduces operating costs
- High output for any commercial application
- No burning pilot light
- Low emissions
- Plastic jacket with 2" environmentally-safe, CFC-free, Polyurethane, water-blown foam insulation
- Less than 1/2 degree F. per hour heat loss (R17)
- Corrosion resistant, high efficiency 90/10 Cupronickel heat exchanger
- Self-diagnostic electronic control featuring digital readout of water temperature, set point, and differential
- Front access cover to equipment is easily accessible
- Optional heat exchanger for floor radiant/baseboard heating
- Temperature range from 70 degrees F. to 180 degrees F.
- Zero clearance to any combustible surface; can be installed in almost any closet!

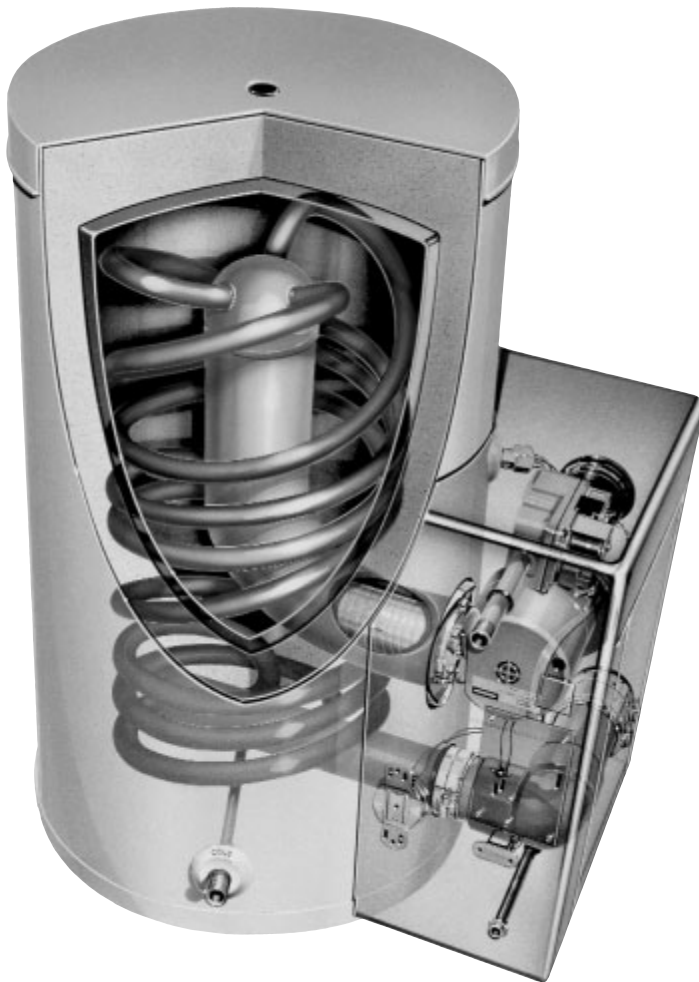

CREATED BY THE MANUFACTURERS OF:

SUPERstor
HEAT TRANSFER PRODUCTS, INC.



**TO REFERENCE VOYAGER MODEL NUMBERS, PLEASE
USE THE FOLLOWING GUIDELINES:**

SSV 130 - 45 S A LP	TEMP. (Deg. F.)	WARRANTY
Series BTU U.S. Temp. Warr. Gas Type Gal. (Deg. F.)	R = 160 S = 180	A = 6 yrs. parts; 6 yrs. comm.; 10 yrs. res. B = 1 yr. parts; 3 yrs. comm.; 10 yrs. res.

SPECIFICATIONS

MODEL	GALLON CAPACITY	INPUT BTU/HR. NAT. & "LP" GAS		TEMPERATURE RISE IN DEGREES FAHRENHEIT										
				40	50	60	70	80	90	100	110	120	130	140
SSV199-119R	119	199,000	GPH	545	436	363	311	272	242	218	198	181	167	155
			GPM	9	7	6	5	4.5	4	3.5	3.3	3	2.7	2.5
SSV & SSVH199-80R	80	199,000	GPH	545	436	363	311	272	242	218	198	181	167	155
			GPM	9	7	6	5	4.5	4	3.5	3.3	3	2.7	2.5
SSV199-45S	45	199,000	GPH	545	436	363	311	272	242	218	198	181	167	155
			GPM	9	7	6	5	4.5	4	3.5	3.3	3	2.7	2.5
SSV160-45S	45	160,000	GPH	436	349	290	249	218	193	174	158	145	134	124
			GPM	7	5.8	4.8	4	3.6	3.2	2.9	2.6	2.4	2.2	2
SSV130-119R	119	130,000	GPH	354	283	236	202	177	157	141	128	118	109	101
			GPM	5.9	4.7	3.9	3.9	2.9	2.6	2.3	2.1	1.9	1.8	1.6
SSV130-80R	80	130,000	GPH	354	283	236	202	177	157	141	128	118	109	101
			GPM	5.9	4.7	3.9	3.9	2.9	2.6	2.3	2.1	1.9	1.8	1.6
SSV130-45R/S	45	130,000	GPH	354	283	236	202	177	157	141	128	118	109	101
			GPM	5.9	4.7	3.9	3.9	2.9	2.6	2.3	2.1	1.9	1.8	1.6
SSVH130-45S	45	130,000	GPH	354	283	236	202	177	157	141	128	118	109	101
			GPM	5.9	4.7	3.9	3.9	2.9	2.6	2.3	2.1	1.9	1.8	1.6
SSV100-45R	45	100,000	GPH	269	215	179	154	134	119	108	98	89	82	77
			GPM	4.4	3.5	2.9	2.5	2.2	1.9	1.7	1.5	1.4	1.3	1.2
SSV90-45S	45	90,000	GPH	245	196	163	140	122	109	98	89	81	75	70
			GPM	4	3.2	2.7	2.3	2	1.8	1.6	1.4	1.3	1.2	1.1
SSVH90-45S	45	90,000	GPH	245	196	163	140	122	109	98	89	81	75	70
			GPM	4	3.2	2.7	2.3	2	1.8	1.6	1.4	1.3	1.2	1.1

Recovery on rating plate is based at 94% thermal efficiency at 100 degrees Fahrenheit rise, as required by A.N.S.I.

MODEL	HEIGHT	WIDTH	SHIP. WEIGHT	DEPTH	MODEL	INPUT	FIRST HR. RATING	VENT SIZE	RECOVERY EFFIC. %
SSV199-119R †	74"	27 1/4"	405 Lbs	36"	SSV199-119R †	199,000	335	3"	94%
SSV199-80R †	72"	23 1/4"	235 Lbs	32"	SSV199-80R †	199,000	300	3"	94%
SSV199-45S	42 1/2"	23 1/4"	175 Lbs	32"	SSV199-45S	199,000	270	3"	94%
SSV160-45S	42 1/2"	23 1/4"	175 Lbs	32"	SSV160-45S	160,000	220	3"	94%
SSV130-119R †	74"	27 1/4"	400 Lbs	36"	SSV130-119R †	130,000	250	2"	94%
SSV130-80R †	72"	23 1/4"	230 Lbs	32"	SSV130-80R †	130,000	220	2"	94%
SSV130-45R*	42 1/2"	23 1/4"	175 Lbs	32"	SSV130-45R*	130,000	180	S-3"/R-2"	94%
SSV100-45R †	42 1/2"	23 1/4"	175 Lbs	32"	SSV100-45R †	100,000	138	2"	95%
SSV90-45S	42 1/2"	23 1/4"	175 Lbs	32"	SSV90-45S	90,000	125	3"	95%

†THESE MODELS ARE ONLY AVAILABLE AS "R" MODELS WITH 160 DEGREES F. MAX. SETPOINT

*THIS MODEL IS ALSO AVAILABLE AS AN "S" MODEL WITH 180 DEGREE F. MAX. SETPOINT AND 3" VENT

MODEL	HEIGHT	WEIGHT	DEPTH	INPUT	FIRST HR. RATING	VENT SIZE	RECOVERY EFFIC. %	HEAT EXCH. BTU	HEAT EXCH.	SHIP. WEIGHT
SSVH 199-80R	72"	23 1/4"	32"	199,000	300 Gallons	3"	94%	140,000	32 sq. ft.	255 Lbs
SSVH 130-45S	42 1/2"	23 1/4"	32"	130,000	180 Gallons	3"	94%	110,000	32 sq. ft.	205 Lbs
SSVH 90-45S	42 1/2"	23 1/4"	32"	90,000	125 Gallons	3"	95%	81,000	32 sq. ft.	205 Lbs

SSVH MODELS HAVE OPTIONAL HEAT EXCHANGER FOR FLOOR RADIANT AND COMBINED HEAT CONNECTION SIZES ARE 1" NPT DOMESTIC INLET, DOMESTIC OUTLET FOR THE 45 GALLON UNITS. CONNECTION SIZES ARE 1 1/2" NPT DOMESTIC INLET, DOMESTIC OUTLET FOR THE 80 & 119 GALLON UNITS.

Note: These overall dimensions are approximate within +/- 1".

Heat Transfer Products reserves the right to change specifications or discontinue models without notice.

VOYAGER LAYOUT

45 GALLON

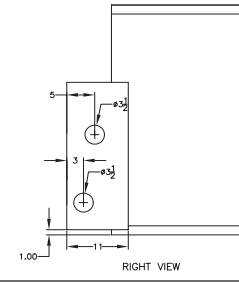
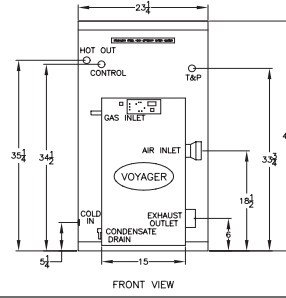
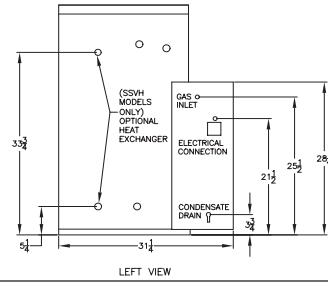
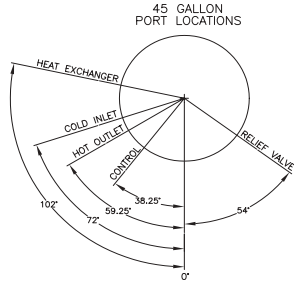

80 GALLON

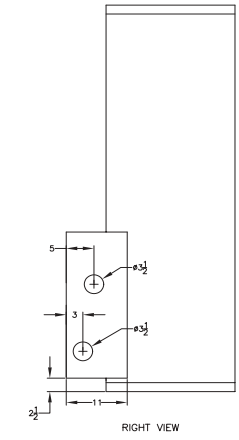
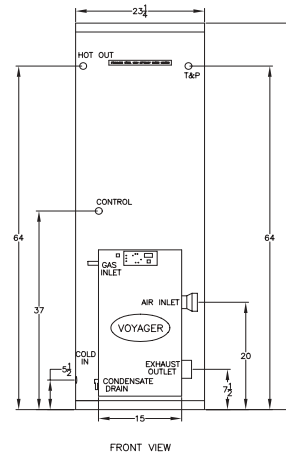
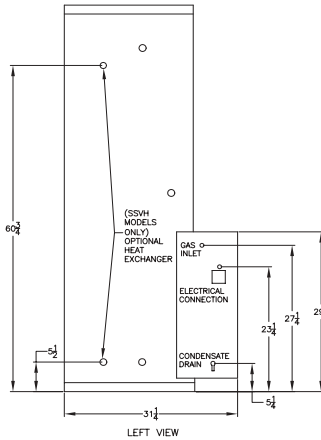
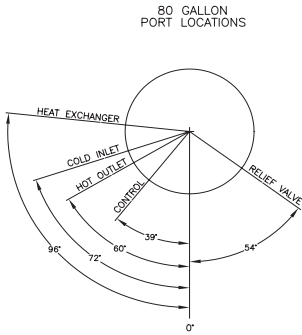

119 GALLON

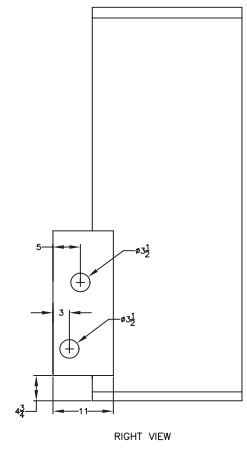
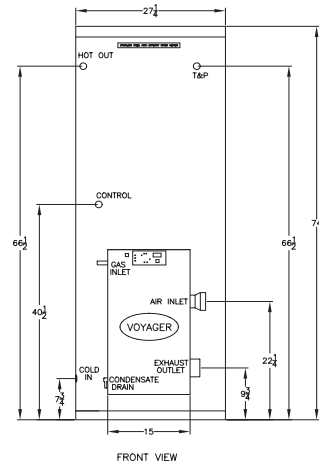
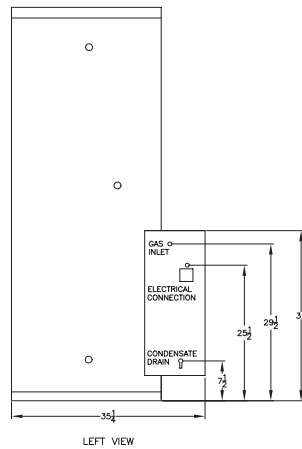
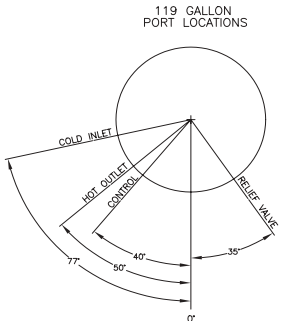

VENTING

SIDE WALL VENTING (SIDE VIEW SHOWN)

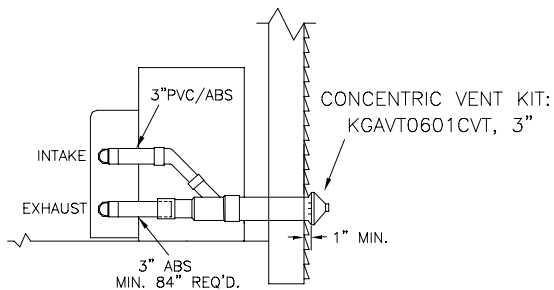

VERTICAL ROOF VENTING (FRONT VIEW)

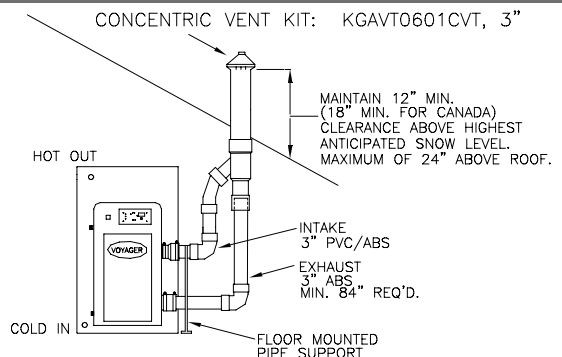

Note: These overall dimensions are approximate within +/- 1".

Heat Transfer Products reserves the right to change specifications or discontinue models LP without notice.

INSTALLATION LAYOUT REFERENCES

COMBINATION WATER HEATING & FLOOR RADIANT HEATING (VOYAGER AS CLOSED LOOP HEAT SOURCE)

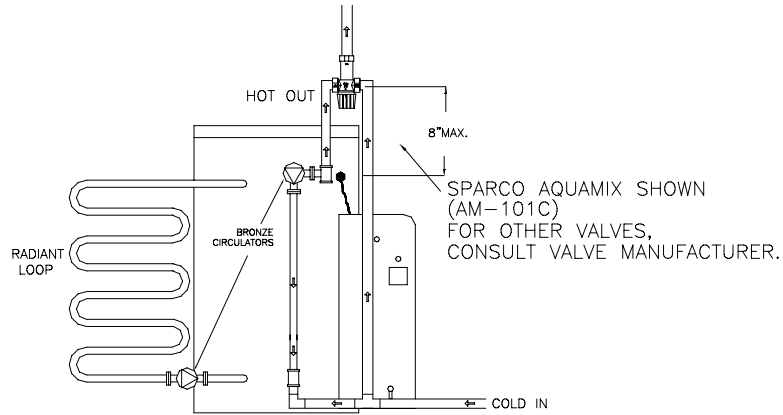

COMBINATION HEATING, COOLING, AND DOMESTIC HOT WATER HEATING

VOYAGER HIGH EFFICIENCY GAS-FIRED WATER HEATERS WITH AIR HANDLERS SHOULD BE INSTALLED BY THE INSTALLING CONTRACTOR BASED ON THE DRAWING SUPPLIED. ANY DEVIATIONS FROM THIS DRAWING PLEASE CONSULT WITH THE FACTORY AT: 1-800-323-9651 ASK FOR TECHNICAL SUPPORT

SPARCO AQUAMIX SHOWN (AM-101C) FOR OTHER VALVES, CONSULT VALVE MANUFACTURER.

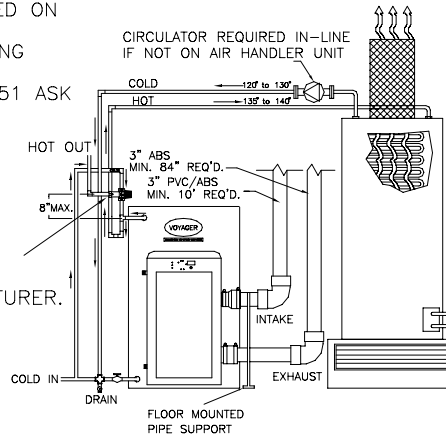

REVERSE MANIFOLD AND PIPING DIAGRAM

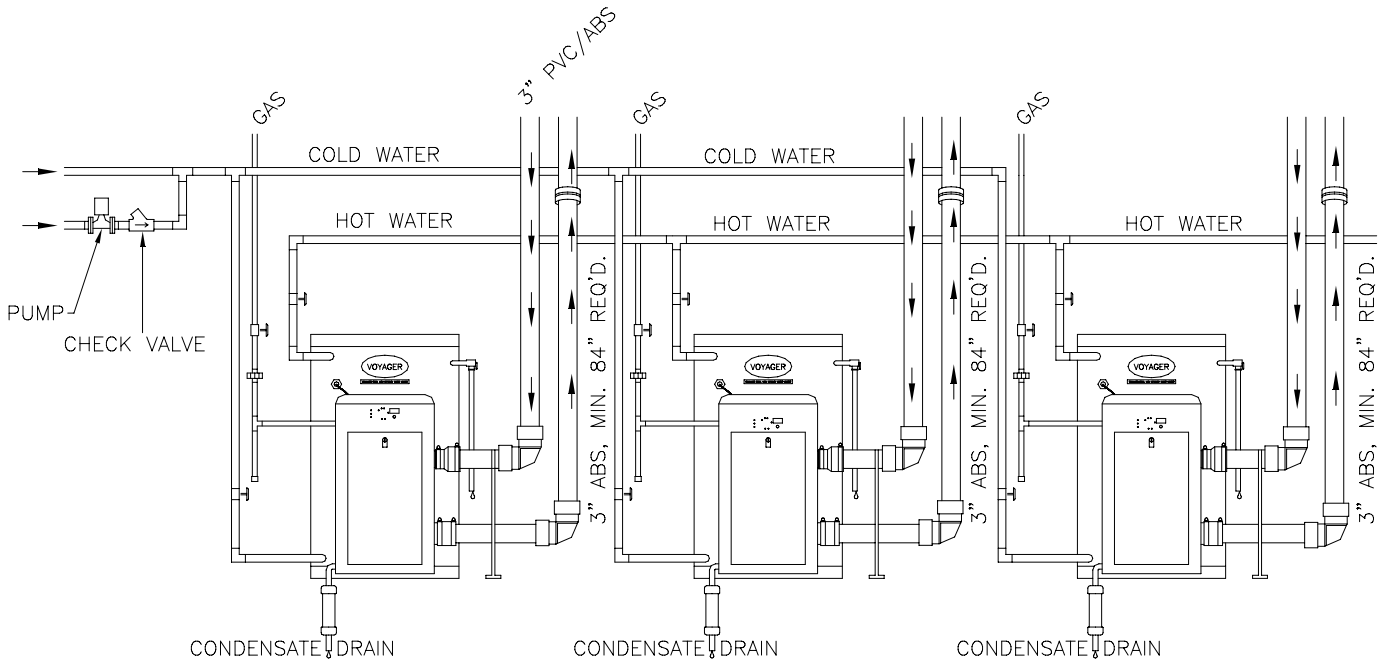

MANUFACTURED BY:

HEAT TRANSFER PRODUCTS, INC.; P.O. BOX 429, 120 BRALEY ROAD, EAST FREETOWN, MA 02717
 SALES, SERVICE, & TECHNICAL SUPPORT: 1-508-763-8071, OR 1-800-323-9651
 OR VISIT US ON THE WEB.....WWW.HTPRODUCTS.COM

The manufacturer reserves the right to make product changes or improvements at any time, with or without notice.